

METAL FITTINGS FOR STRIP CURTAIN

Different sheet fittings can be chosen according to site requirements.

MC series · ZS series

Common structure for installation, with variety of overlap rates and it can use different fittings according to opening dimensions.

A-MC Fixing type

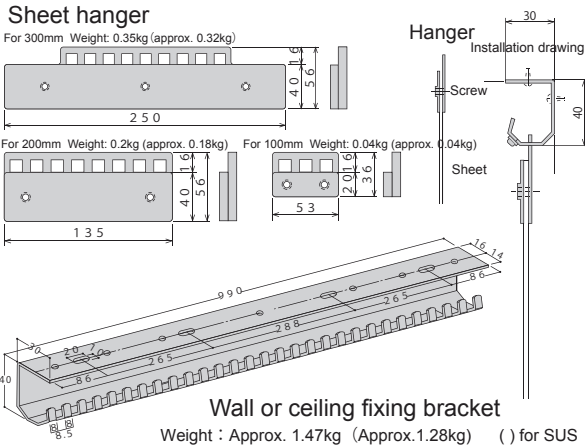

SW series

With the sheet hanger and bracket in strong durability. Suitable for such sites where there are many traffic of carts as plants or warehouses.

A-SW Fixing type for sheet width 200mm and 300mm

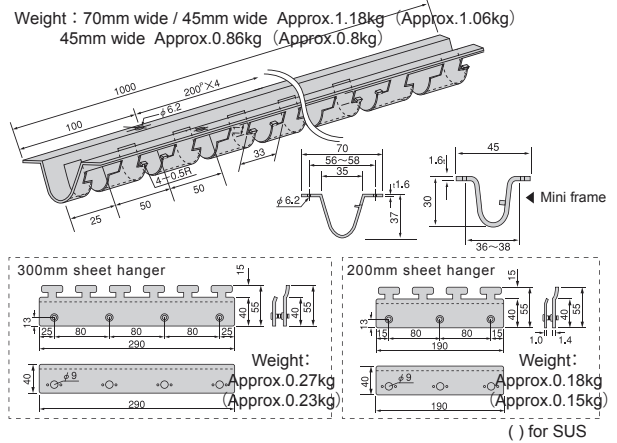

B-ZS Sliding type

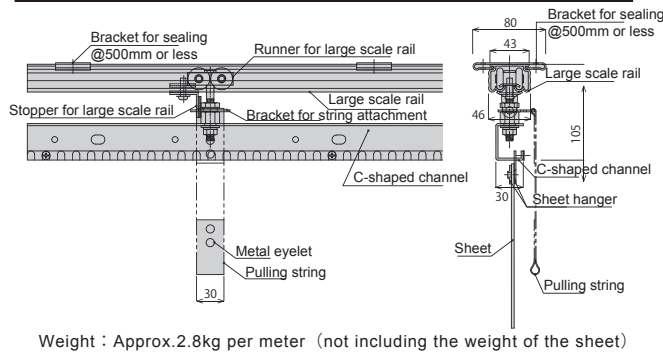

B-SW Sliding type for sheet width 200mm and 300mm

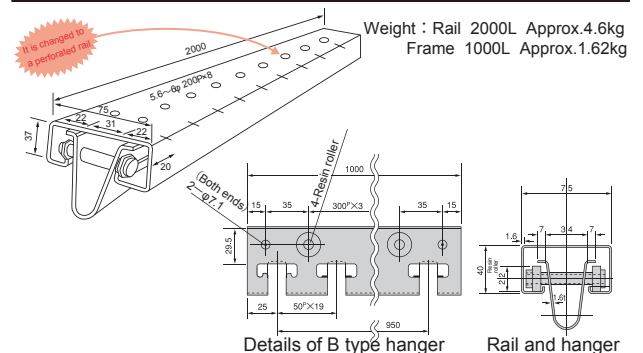

C-ZS Accordion type

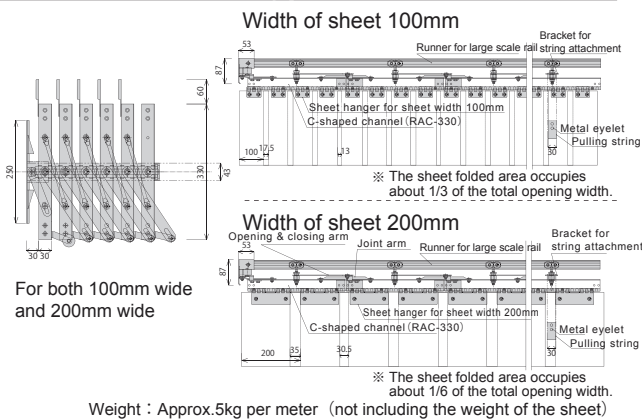

Width of sheet 300mm

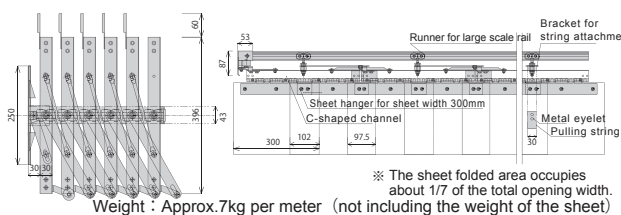

C-SW Accordion type for sheet width 300mm

